



## THE CHEF'S DRAWER

Provides bulk storage of fresh or frozen food right where you need it. Its low level height is perfect for suiting with many prime cooking stations and you can stack Chef's Drawers for the ultimate in fridge / freezer flexibility.



## THE CHEF'S DRAWER

The Chef's Drawer is a large, space saving refrigerated drawer unit, an ideal solution for pubs, steakhouses and catering facilities where space is often limited.

Available in two sizes/formats depending on application, both models provide flexibility and control, allowing the operator to set the unit's temperature as refrigerated or freezer storage, anywhere between +1 to -22°C.

At just 670mm deep, the **VSWCD1** is ideal for standard 700mm work-surfaces, leaving 30mm extra depth for plug sockets. Two stacked units will fit under a 900mm high work-surface.

The **VRWCD1** model fits perfectly with popular prime cooking suites, such as Falcon Foodservice Equipment's F900 Series (Dynamic Link System). Models are available as a refrigerator or freezer and can be stacked for added flexibility, maximising product footprint.

Williams Chef's Drawers are designed to be robust and are built using tough stainless steel both for the exterior and interior. Ingredients can be stored within the self contained drawer of all models which can also accommodate 2/1 GN pans, up to an impressive depth of 150mm.

The units have removable drawers and fittings for ease of cleaning. Their cassette type refrigeration systems are also easily removable, helping facilitate convenient on-site servicing and maintenance.

The height of the Chef's Drawer can be varied thanks to a choice of three different sizes of swivel and brake castors, which also offer mobility and stability when positioning, or the option of adjustable legs.

All models are fitted with the Williams CoolSmart controller and have been designed to perform in an ambient environment of up to 43°C.

- Drawer size 2 x 1 GN (150mm maximum depth)
- Removable refrigeration system designed for easy on-site service and maintenance (VRWCD1 models only)
- Hydrocarbon natural refrigerant
- CoolSmart controller
- Precision injected, high density polyurethane insulation with low GWP (Global Warming Potential) and zero ODP (Ozone Depletion Potential)
- Heavy duty, non-marking swivel castors with brakes
- Stacking capability helps maximise storage capacity
- Front-breathing and rear/side venting refrigeration system
- High performance helium leak testing
- Magnetic balloon drawer gaskets with 100% tight seal

### TECHNICAL DATA

	Temp	Width (mm)	Depth (mm)	Height (mm)	Capacity	Energy Grade
VRWCD1	+1/+4°C or -18/-22°C	880 (677)	850 (522)	528 (268)	94 (3.3)	D
VRWCD1S - Stacked*		880 (677)	850 (522)	928 (268 per section)	188 (6.6)	D
VSWCD1	+1/+4°C or -18/-22°C	1100 (690)	670 (553)	486 (190)	105 (3.7)	D
VSWCD1S - Stacked*		1100 (690)	670 (553)	838 (190 per section)	210 (7.4)	D

Unit dimensions are shown external(internal). Capacities are shown in Litres(cu.ft).

\* Please note that these models have a separate power supply per drawer section

VSWCD1S (Stacked)



VRWCD1



WILLIAMS CHEF'S DRAWERS  
STACKED VSWCD1S

76mm  
CASTORS

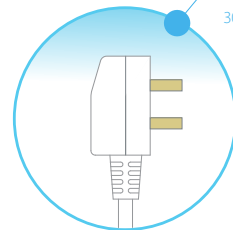
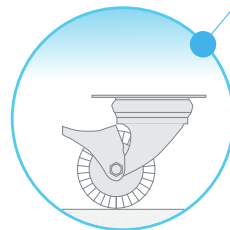
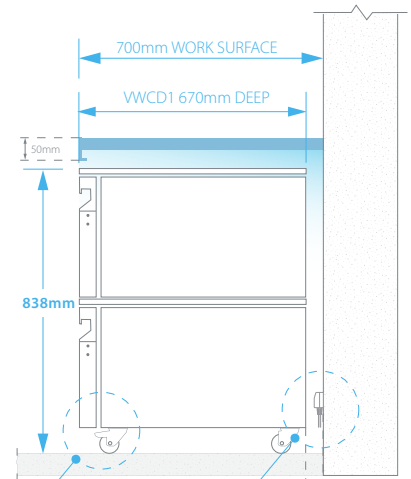
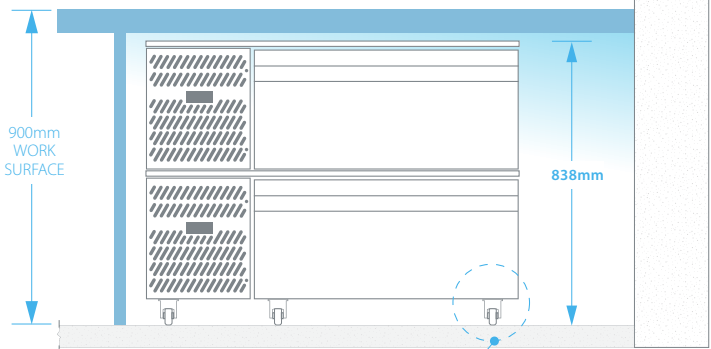

HEIGHT OPTIONS

	Castors (106mm)	Castors (128mm)	Low level Castors (76mm)	Legs (100mm-150mm)
VRWCD1	506	528**	476	500 to 550
VRWCD1S - Stacked	906	928**	876	900 to 950
VSWCD1	486**	508	456	480 to 530
VSWCD1S - Stacked	868	890	838**	862 to 912

\*\* Size of castor fitted as standard.



[www.williams-refrigeration.co.uk](http://www.williams-refrigeration.co.uk)

**Williams Refrigeration**  
 Bryggen Road  
 North Lynn Industrial Estate  
 King's Lynn  
 Norfolk PE30 2HZ  
 T +44 (0) 1553 817 000  
 F +44 (0) 1553 817 111  
 E [info@williams-refrigeration.co.uk](mailto:info@williams-refrigeration.co.uk)



Installation of all Williams products requires adequate ventilation.  
 Williams reserves the right to modify the design, materials and finish in accordance with its progressive development policy.

Williams Refrigeration is a trading name of AFE Group Limited.  
 Registered in England & Wales under Registered Number 3872673.  
 Registered Office Address - Bryggen Road, North Lynn Industrial Estate, Kings Lynn, Norfolk, PE30 2HZ

An Ali Group Company



The Spirit of Excellence